

# Activities of Our Municipal Solid Waste Treatment Plant Business

## A leading company in the industry

Since completing Japan's first fully continuous mechanical waste incineration plant in 1963, Takuma has built more than 350 waste incineration plants in the country, more than any other company in the industry.

We have consistently led the municipal solid waste treatment industry, for example by starting operation of Japan's first combined facility comprised of waste incineration and biogas recovery plants and building numerous high-efficiency waste-fueled power plants.

Takuma will continue to contribute to the realization of a recycling-based society as the industry's leading company.



Combined facility comprised of waste incineration and biogas recovery plants  
(Delivered in 2013 to Nantan Regional Administrative Association)



High-efficiency waste-fueled power plant  
(processing capacity: 163 tons per day)  
(Delivered in 2016 to Kurume City)



High-efficiency waste-fueled power plant  
(processing capacity: 600 tons per day)  
(Delivered in 2014 to the Clean Authority of Tokyo)



High-efficiency waste-fueled power plant  
(processing capacity: 110 tons per day)  
(Delivered in 2016 to the Neighborhood of the Lake Administrative Affairs Association)

## From construction to after-sales service

Takuma's municipal solid waste treatment plant business consists of four components: plant construction, primary equipment improvement, maintenance, and long-term turnkey operation.

In each area of operations, we draw on technological capabilities and expertise based on our extensive experience to precisely meet the needs of local governments, regions, and society, allowing us to offer facilities that are welcomed by their communities.

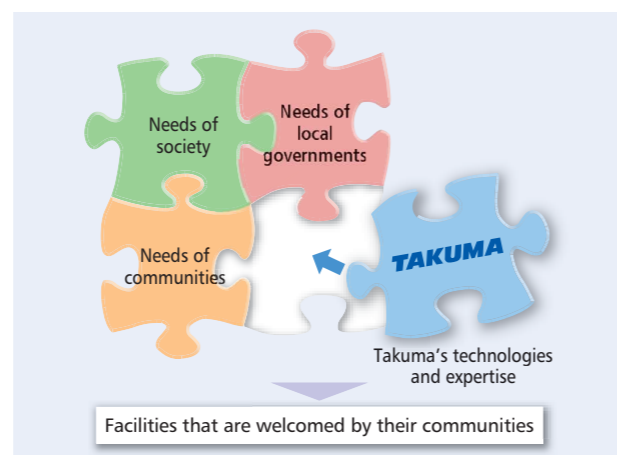

## 1 Plant construction

### Stoker-type incinerators

Most Energy from Waste plants use stoker-type incinerators. Takuma has been delivering stoker-type incinerators to customers for half a century, allowing us to accumulate a variety of expertise in areas such as stable combustion, exhaust gas treatment, and waste-fueled power generation.

Based on this well-established base of technological capability, we build and supply highly efficient waste treatment systems by integrating the latest technologies, for example water-cooled stokers, proactive combustion control, exhaust gas recirculation systems, and furnace denitration and urea decomposition systems.

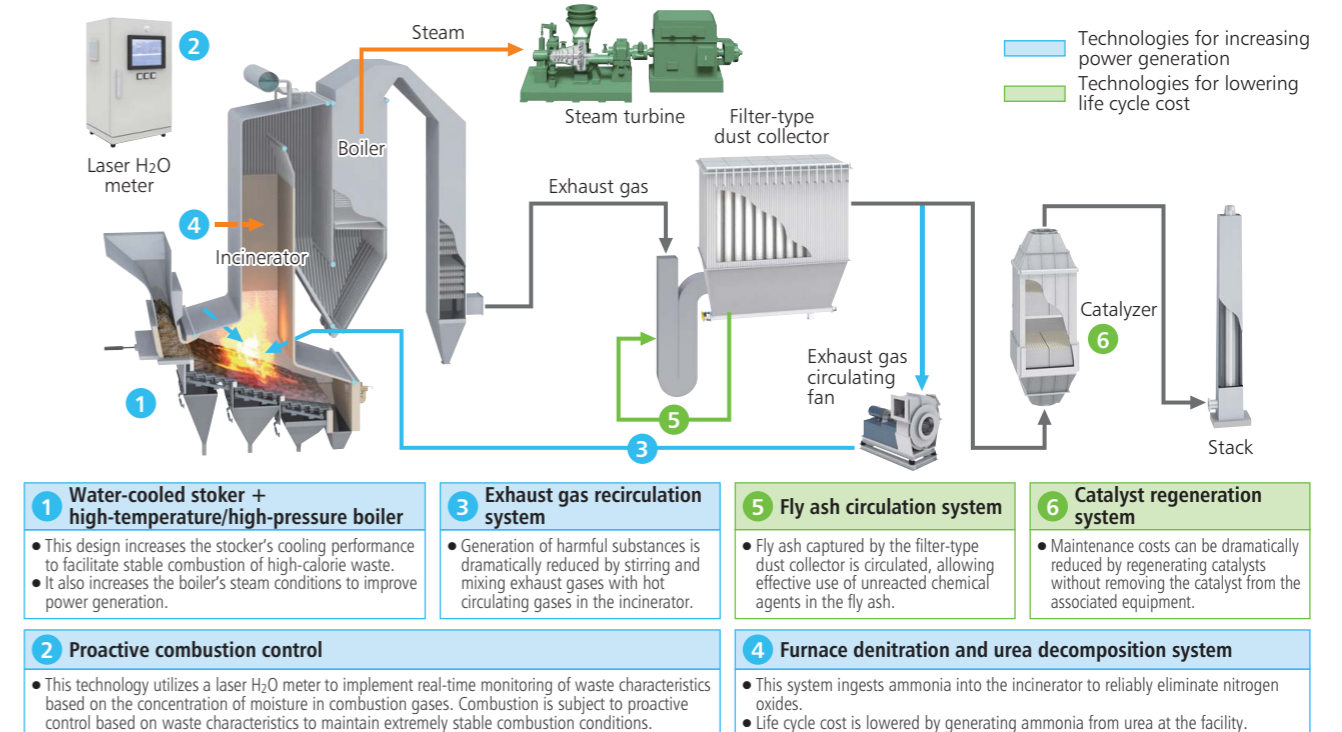

### Biogas recovery plants

Recently the Ministry of the Environment has been encouraging the introduction of biogas recovery plants for use with municipal solid waste. This is an area where Takuma is helping further lower CO<sub>2</sub> emissions with a combined system of methane fermentation and incineration for municipal solid waste to recover the maximum amount of energy from the waste treatment and utilize it in high-efficiency power generation. (The system received the New Energy Foundation's Chairman Award at the FY2014 New Energy Awards.)

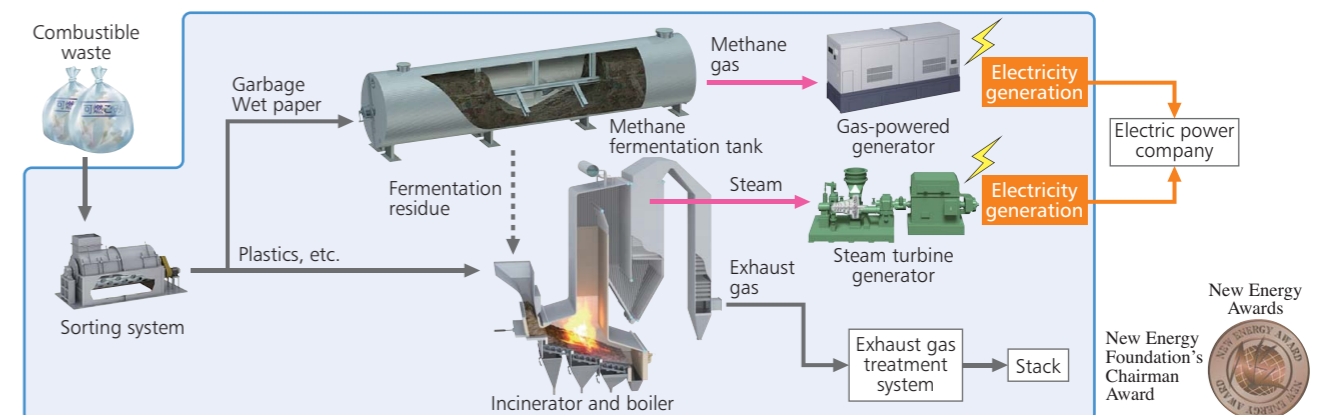



## Activities of Our Municipal Solid Waste Treatment Plant Business

### 2 Primary equipment improvements



#### Implementing high-value-added renovations

Although waste treatment plants are required to operate over extended periods of time, equipment must be renovated once 20 or more years has passed since the plant began operating. In addition, changes in the regulatory environment and society sometimes make large-scale renovations necessary.

Takuma draws on the sophisticated heat utilization technologies and energy-saving technologies it has accumulated as a boiler and environmental plant manufacturer to carry out high-value-added and large-scale renovation projects. In this way, we are able to help extend facilities' service life while lowering CO<sub>2</sub> emissions.

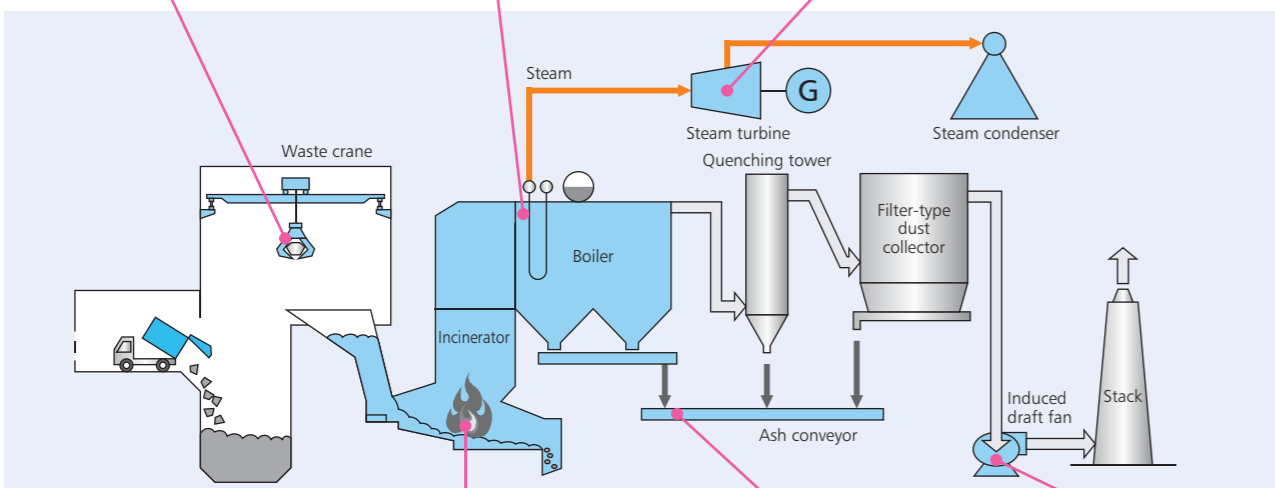
<h4>Installation of inverters on cranes</h4> <ul style="list-style-type: none"> <li>Reducing power by installing speed control-type inverters</li> </ul> 	<h4>Improvement of heat recovery</h4> <ul style="list-style-type: none"> <li>Installing boilers on water-injection furnaces</li> <li>Expanding boilers' heating surface</li> </ul> 	<h4>Improvement of steam turbine capacity</h4> <ul style="list-style-type: none"> <li>Improving generating capacity by increasing steam intake capacity and optimizing design features</li> <li>Improving the capacity of steam condensers</li> </ul> 
---	---	---



<h4>Enhancement of combustion equipment efficiency</h4> <ul style="list-style-type: none"> <li>Improving stable combustion by changing furnace shape and stabilizing the volume of steam generation and power generation</li> <li>Reducing the volume of exhaust gases and increasing the volume of heat recovery by adopting low-air-ratio combustion technology</li> </ul> 	<h4>Adoption of high-efficiency motors</h4> <ul style="list-style-type: none"> <li>Reducing power use by adopting high-efficiency motors</li> </ul> 	<h4>Installation of inverters on fans</h4> <ul style="list-style-type: none"> <li>Reducing power use by installing speed control-type inverters</li> </ul> 
--	--	--

Examples of primary equipment improvement works

### 3 Maintenance

#### Ensuring stable waste treatment

Annual maintenance is essential in order to ensure stable operation of waste treatment plants. However, maintenance demands both sophisticated technological capabilities and experience, both because waste treatment plants draw on a range of expertise and because the manner in which their equipment deteriorates over time varies with the properties of the waste they process. Takuma takes maximum advantage of its accumulated expertise to contribute to stable waste treatment and long-term facility operation by developing long-term repair plans, carrying out elaborate site investigations, and then performing maintenance that has been optimized in terms of both timing and content.



Repairing an incinerator's refractory

Measuring the thickness of boiler water tubes

Maintaining a conveyor

### 4 Long-term turnkey operation business

#### High-quality facility operation using POCYS<sup>®</sup>, a comprehensive support system for operation, maintenance, and management

Our long-term comprehensive operation business, in which we offer contract operation, maintenance, and management services over a period of 10 to 20 years, has been growing in recent years. As of May 2017, the Takuma Group operates 16 facilities.

We are working to increase the quality of our operation, maintenance, and management services by progressively deploying POCYS<sup>®</sup>, a system that we developed during FY2016, at the facilities we operate. POCYS<sup>®</sup> makes it possible to achieve even more stable operation by analyzing enormous volumes of accumulated data, for example to facilitate more sophisticated automatic combustion control. (\*POCYS<sup>®</sup>: Plant Optimization Comprehensive Support System)

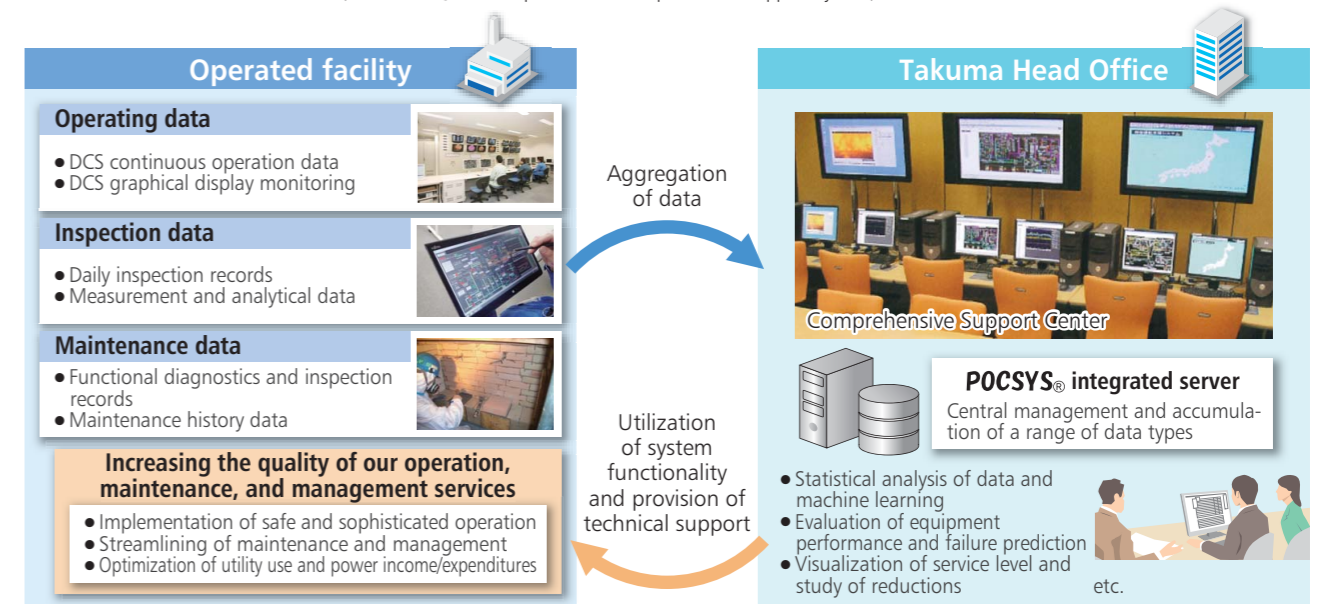

POCYS<sup>®</sup> conceptual diagram

# Activities of Our Energy Plant Business

—Transforming a variety of biomass resources into fuel

## Technologies and experience in using a broad range of biomass fuels

Since its founding, Takuma has enhanced its technological capabilities as a pioneering boiler manufacturer to deliver a total of more than 600 boilers designed to accommodate a wide variety of biomass fuels in Japan and overseas.

Going forward, we will continue to actively pursue development and improvement of technologies for effectively using energy in a way that gives priority to both humankind and the planet while simultaneously meeting customer needs.

### Social landscape

The Great East Japan Earthquake of 2011 threw the safety of nuclear power plants into question and led many to begin focusing on “renewable energy,” which is characterized by a low environmental impact, as an alternative source of energy. Biomass-fueled power generation in particular promises beneficial ripple effects such as redevelopment of the forestry industry and job creation as companies move to fill needs of fuel procurement, transport, and storage as well as chip processing and other operations. Compared to solar and wind power, biomass also has the advantage of being able to provide power in a relatively stable manner without being affected by weather. Currently, biomass-fueled power plants are being planned and built in locations across Japan.

## Renewable energy

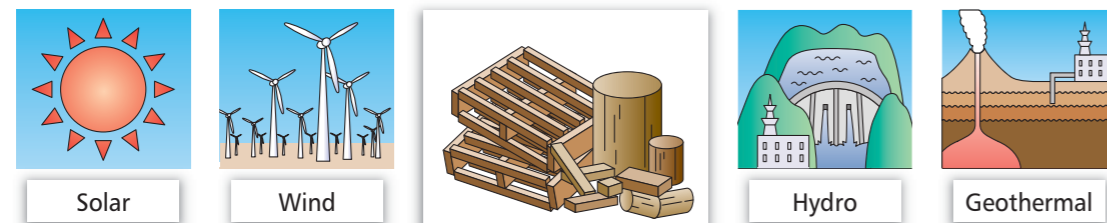

## Biomass

### Forestry-derived biomass fuels

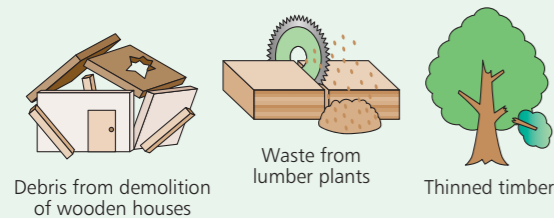

### Industry-derived biomass fuels

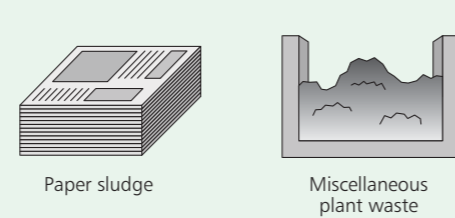

### Livestock-derived biomass fuels

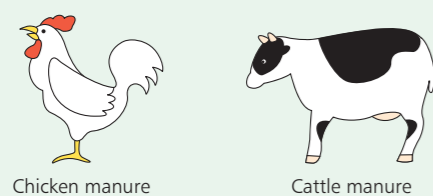

### Agriculture-derived biomass fuels

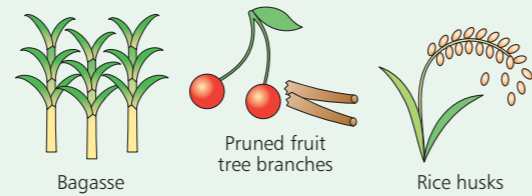

## Delivery record of biomass boilers by area of Japan

Takuma is working on facilities that use biomass fuel throughout Japan.

- We have constructed facilities that use forestry-derived biomass fuels such as thinned timber and waste from lumber plants and industry-derived biomass fuels such as plant waste and sludge from manufacturing plants in many regions.
- We have constructed many facilities in Japan that use livestock-derived biomass fuels such as chicken and cattle manure and agriculture-derived biomass fuels such as bagasse (fiber remaining after sugarcane is crushed and sugar extracted), particularly in Kyushu and Okinawa.

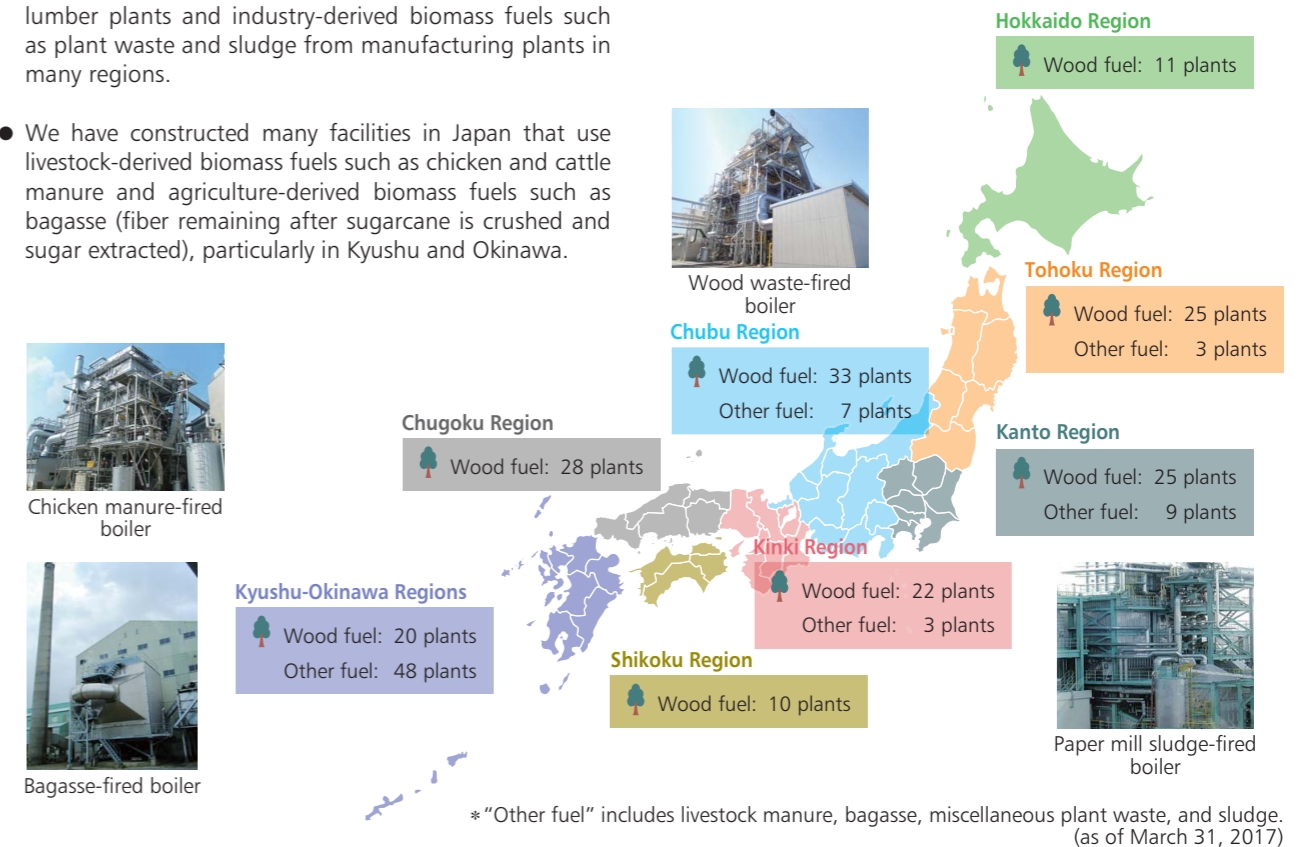

## VOICE Sales activities from the customer's perspective

Planning of biomass-fired power plants has surged due to the effects of Japan's feed-in tariff (FIT) program for renewable energy, which entered into effect in July 2012. As a result, our sales departments have been receiving a large number of inquiries for such facilities.

Our primary focus as we work to accommodate those inquiries is on pursuing sales activities from the customer's perspective. Since numerous companies from other industries are entering the FIT business, we work in our daily sales activities to build trust by addressing the concerns of customers with little experience in plant operation and to offer the best possible proposal for each customer.

Negotiations typically entail considerable difficulty, but I look forward to working through various obstacles and challenges in an optimistic and constructive manner while communicating closely with involved parties both inside and outside the company.



**Junya Yamada**  
 Section 1  
 Plant Sales Department 1  
 Energy Plant Division &  
 Manager  
 Section 1, Hokkaido Branch  
 Takuma Co., Ltd.

# Activities of Our Energy Plant Business

## —Pursuing biomass power generation

Biomass-fired power plants comprise one of our most skilled product areas. Activity in the segment has been sparked by the prospect of stable profits made possible by the launch of Japan's feed-in tariff system for renewable energy, and Takuma has received orders for numerous plants.

We have also received multiple orders for boiler fuel conversion projects to provide electricity and steam for internal plant use.

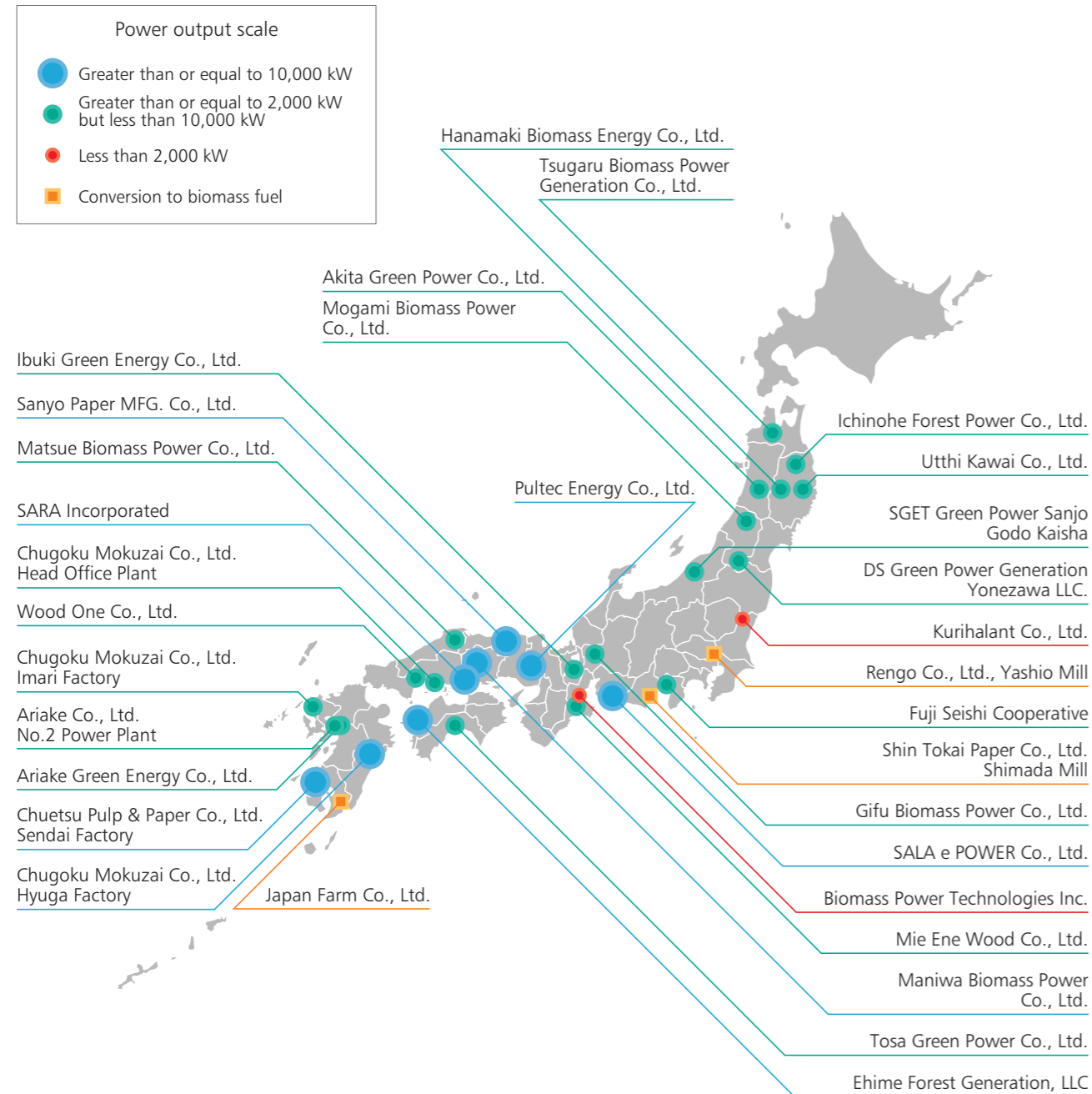

\* Biomass-fired power plants ordered during or after July 2012 (as of March 31, 2017)

### Proposing combustion furnaces that can accommodate the fuels customers use

#### Step grate stoker

This combustion method, which derives from waste incineration technology, can be used to uniformly burn fuels with different calorific values, moisture content, shapes, and sizes. Another characteristic of this method is that it requires less power to operate (known as facility power) than other types.

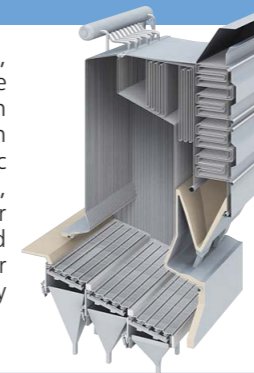

#### Installation example: Sendai Factory, Chuetsu Pulp & Paper Co., Ltd.

Chuetsu Pulp & Paper Co., Ltd. is a large general paper manufacturer that manufactures, processes, and sells pulp and paper products.

The facility we delivered at the company's Sendai Factory uses a step grate stoker that can accommodate biomass fuels with a variety of properties and shapes in anticipation of the future diversification of fuels.

- [Equipment overview]
- Location: Satsumasendai City, Kagoshima Prefecture
  - Power output: 23,700 kW

#### Traveling stoker

With a traveling stoker, fuel is distributed in the furnace so that longer combustion times are secured for fuel with larger volumes. As with a step grate stoker, combustion is comparatively gradual, and the system can accommodate a wide range of fuels with different calorific values, moisture content, and shapes.



#### Installation example: Ariake Green Energy Co., Ltd.

Ariake Green Energy Co., Ltd. is a wood chip biomass-fueled power plant operator established with investments by Ishizaki Inc.; Kyushu Biotech Co., Ltd.; and Matsumoto Mokuzai Co., Ltd.

This plant uses scrap lumber and other wood waste from lumber mills in Kumamoto Prefecture as well as unused lumber such as wood from thinned trees as biomass fuel. The business is expected to yield a variety of benefits, including the revitalization of the forestry industry and the local community through job creation.

- [Equipment overview]
- Location: Arao City, Kumamoto Prefecture
  - Power output: 6,250 kW

#### Bubbling fluidized bed

Since sand that has been fluidized by high-pressure air burns away the surface of the chips, little unburned fuel remains, making high boiler efficiency a characteristic of fluidized bed systems. They can accommodate a variety of different types of fuel, including fuels with high moisture content.



#### Installation example: Hanamaki Biomass Energy Co., Ltd.

Hanamaki Biomass Energy Co., Ltd. is a wood chip biomass power plant operator established by a group of investors led by Takeei Corporation.

This plant makes effective use of unused lumber such as wood from thinned trees from Iwate Prefecture's lush forests and lumber damaged by pine weevils to create renewable energy.

- [Equipment overview]
- Location: Hanamaki City, Iwate Prefecture
  - Power output: 6,250 kW

#### Circulating fluidized bed

Heated, fluidized sand burns fuel as it circulates, keeping temperatures inside the furnace uniform to enable stable combustion. Since little waste remains unburned, boiler efficiency is high, and the system can accommodate a broad range of mixed fuels with different caloric values.

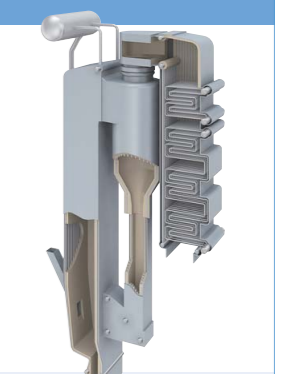

#### Installation example: Hyuga Factory, Chugoku Mokuzai Co., Ltd.

Chugoku Mokuzai Co., Ltd. is a large general lumber company that offers an extensive product line ranging from lumber to laminated lumber and pre-cut lumber.

The facility delivered by Takuma to the company's Hyuga Factory uses a circulating fluidized bed boiler that can accommodate the customer's need to effectively utilize a wide range of biomass fuels.

- [Equipment overview]
- Location: Hyuga City, Miyazaki Prefecture

# Activities of Our Water Treatment Plant Business

More than 50 years have passed since Takuma entered the water treatment business. To date, we have helped improve the water environment by building water treatment facilities. Recently, the industry has been called upon not only to improve the water environment, but to reduce the amount of power that treatment equipment consumes and to create energy from sludge.

This section introduces some of Takuma's recent initiatives, using a sewage treatment plant as an example.

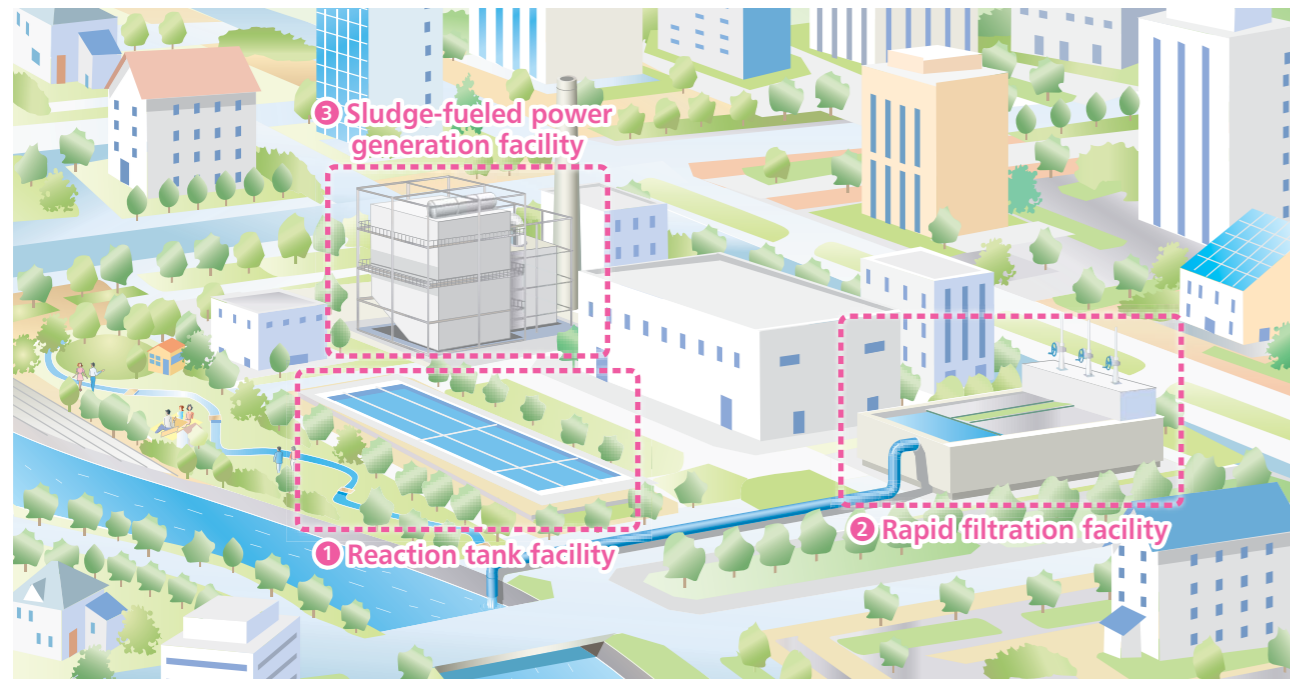

## 1 Reaction tank facility

A bioreactor tank, which provides the primary type of water treatment at the site, purifies sewage through the action of microorganisms. Takuma's low-power agitator plays a key role by reducing the power consumption requirements of agitating activated sludge to one-third of those of a conventional facility.



Installation example  
(Higashiujii Sewage Treatment Plant, Uji City)

### VOICE Stable operation over the long term



**Masanobu Fukuzawa**  
Section 1  
Sewerage Engineering  
Department  
Project Center  
Takuma Co., Ltd.

In this project, we replaced an outdated reaction tank facility with a state-of-the-art energy-saving system and introduced advanced treatment capable of removing nitrogen and phosphorus. The latter can be expected to improve the quality of treated sewage, to protect water quality where treated discharge is discharged, and to prevent eutrophication, which causes phenomena such as red tides, in Osaka Bay. It is our hope that the facility in whose design and construction I was involved will operate in a stable manner over the long term and play a useful role in protecting the water environment.

## 2 Rapid filtration facility

A sand filtration facility removes even smaller suspended particles in water that has already passed through the reaction tank and sedimentation basin. This type of facility is necessary when the river into which treated sewage is discharged is subject to strict water quality requirements or when the treated sewage will be reused. Moving-bed sand filtration facilities, which are a specialty of Takuma's, deliver energy and space savings along with stable performance. To date, we have delivered more than 2,500 such systems throughout Japan.



Installation example  
(Edagawa Sewage Treatment Plant, Nishinomiya City)

### VOICE

### Helping protect water quality where treated sewage is discharged



**Yoshinobu Konomi**  
Section 2  
Construction Department  
(Osaka)  
Construction Center  
Takuma Co., Ltd.

In this project, we installed a new filtration facility capable of treating about one-third of the entire throughput of the Edagawa Sewage Treatment Plant (about 30,000 m<sup>3</sup> per day). This type of system is installed inside a tank, so it's difficult to picture what it looks like, but a creative approach is required in order to fit it into the available space since it has a large number of components. I was responsible for the construction process as the project's field representative. We completed that process without incident in about six months thanks to support from the customer and numerous other involved parties. I hope that through this construction project we will be able to help protect water quality where treated sewage is discharged.

## 3 Sludge-fueled power generation facility

Sludge, which is a byproduct of the sewage treatment process, contains a large amount of energy. As a result, it has been attracting attention in recent years as a type of biomass.

Takuma harnesses its core incineration and boiler technology to make effective use of sludge as fuel for power generation to create electricity.

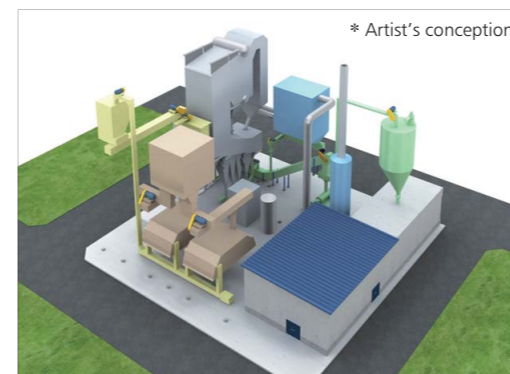

Installation example  
(Tama River Water Recycling Center  
[currently under construction], Tokyo)

### VOICE

### Contributing with the latest systems



**Hiroki Wada**  
Section 2  
Sewerage Engineering  
Department  
Project Center  
Takuma Co., Ltd.

The new sludge-fueled facility we're building in this project is a state-of-the-art system that incorporates steam power generation into a stoker furnace and waste heat boiler that was ordered by the Tokyo Metropolitan Government's Bureau of Sewage to fulfill a high-temperature, energy-saving furnace and generator procurement project. The facility will generate 137 kW from incineration of 140 tons of sludge per day. We'll be working with the Tokyo Metropolitan Government and other involved companies to complete the project safely and reliably by the end of FY2019.

# Activities of Our Overseas Business

## Biomass-fueled power plant business in the Southeast Asian market

The biomass-fueled power generation boiler business in Southeast Asia is an essential part of any discussion of Takuma's history. We have delivered more than 370 biomass boilers to customers overseas, and we have an especially extensive track record since 1959 of delivering boilers fueled by bagasse (fiber remaining after sugarcane is crushed) in Thailand, where we have a local subsidiary. Takuma has supported the Thai sugar industry for many years.

As the feed-in tariff program becomes increasingly well established in various industries, a growing number of customers in Thailand are looking beyond simply gaining a source of power for plant operation and instead opting to construct boilers with the goal of using 10 MPa/520°C class boilers that operate at comparatively high temperature and high pressure levels to actively generate electricity for resale to boost their income. In this way, demand for this type of boiler facility is expected to continue to grow.

Under these conditions, we look forward to helping supply environmentally friendly power from biomass, particularly in Southeast Asia, by accommodating demand not only in Thailand, but also in neighboring countries such as Indonesia and Vietnam with reliable technology and fine-grained customer service based on our extensive experience in the field.



Bagasse-fired boiler installation example

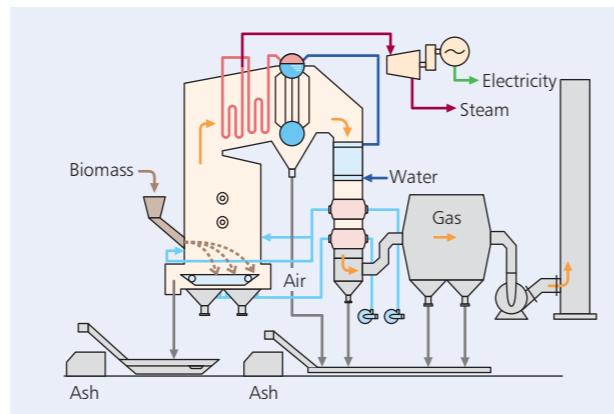

Sugarcane deliveries



Bagasse yard

### VOICE Contributing to energy supply overseas

The first time I visited a sugar factory in Thailand, I was amazed at the scale of the facility. At the same time, I was impressed that one of our boilers was serving as the plant's source of power. We've delivered numerous boilers overseas, and I think that this experience has served to further hone our biomass combustion technology. I look forward to doing my best to help supply energy locally through diligent sales activities so that we will be able to pass that legacy on to the next generation of Takuma engineers intact.



**Takahiro Akaishi**  
 Manager, Sales Section  
 Energy Plant Sales Department  
 International Operations Division  
 Takuma Co., Ltd.

## Overseas Energy from Waste plant business

Waste processing problems have been manifesting themselves in countries around the world recently due to the effects of rapid urbanization, and there have been reports of the adverse effects of burying waste as-is on living conditions, including soil pollution and fires, especially in developing nations. These countries have embarked on initiatives to resolve waste processing issues, but the fact remains that they require even more sophisticated waste processing diagnostic expertise, advice, and guidance.

Takuma has deep experience and an extensive track record that together make it a market share leader in waste incineration and processing equipment in Japan. The photograph below depicts a plant that we delivered in Beijing, China, but in fact we have delivered plants in nine overseas countries and regions, including China and the UK. Our Lakeside Plant in the UK and our Gaoantun Plant in Beijing have earned a high level of praise and trust from their respective customers, for example due to the facilities having achieved continuous operation for more than 8,000 hours a year.

We look forward to taking advantage of our extensive experience to closely exchange information and engage in partnerships with local stakeholders as we offer optimal proposals that meet the full array of needs using technological capabilities in which we have great confidence.

Apart from plant construction, numerous issues must be addressed in order to resolve waste processing problems, including methods for collecting and sorting waste, awareness-raising and environmental education, and consensus-building with local residents. While it takes time to resolve each of these in turn, we are confident that it is precisely by cooperating with such initiatives that we can best provide safe, stable plants that inspire pace of mind on the part of people in their host countries and communities.

Going forward, Takuma will continue to contribute to environmental protection by pursuing an overseas Energy from Waste plant business that suits each country and community.



**Beijing Gaoantun Energy from Waste Plant (China)**

- Processing capacity: 1,600 tons per day (800 tons per day × 2 units)
- Steam capacity: 73.8 tons per hour
- Steam pressure: 4.0 MPa
- Steam temperature: 400°C
- Rated power output: 15,000 kW × 2 units

### VOICE Helping solve environmental problems overseas

Waste incineration facilities, which are one of Takuma's flagship products, are one type of essential infrastructure that numerous developing nations in Asia expect to construct in the future. Although the market environment, for example in terms of laws, has not yet been put in place in those countries, I'm involved in large-scale projects related to developing associated mechanisms. I find my job motivating from the standpoint of being able to help resolve environmental problems in developing nations.



**Masaya Kawamoto**  
 Sales Section  
 Environmental Plant Sales Department  
 International Operations Division  
 Takuma Co., Ltd.

# Main Recent Projects

The following are the main facilities supplied by Takuma during FY2016.

## Municipal solid waste treatment plants

### ■ New construction (DBO projects)

\* More information about the following projects can be found in "Feature: Striving to Coexist with Local Communities" on pages 17 to 22.

#### ● Miyanojin Clean Center



Project name Northern Kurume Solid Municipal Waste Treatment Facility Development and Operation Project  
 Capacity Incineration facility: 163 tons per day (81.5 tons per day × 2 units)  
 Power output: 3,560 kW  
 Location Fukuoka Prefecture

#### ● Clean Park Hokutan



Project name Hokutan Waste Treatment Facility Development and Operation Project  
 Capacity Incineration facility: 142 tons per day (71 tons per day × 2 units)  
 Power output: 2,850 kW  
 Location Hyogo Prefecture

#### ● Suwa Lakeside Clean Center



Project name Lakeside District Waste Treatment Facility Development Project  
 Capacity Incineration facility: 110 tons per day (55 tons per day × 2 units)  
 Power output: 2,050 kW  
 Location Nagano Prefecture

### ■ Primary equipment improvements

#### ● Kogasaki Incineration Facility City of Kitakyushu



Project name Kogasaki Plant Incineration Facility Improvement Project  
 Capacity Incineration facility: 810 tons per day (270 tons per day × 3 units)  
 Power output: 17,200 kW  
 Location Fukuoka Prefecture

#### ● Mattoishikawa Environmental Clean Center



Project name Mattoishikawa Environmental Clean Center Primary Equipment Improvement Project (Plant Construction)  
 Capacity Incineration facility: 240 tons per day (80 tons per day × 3 units)  
 Power output: 2,900 kW  
 Location Ishikawa Prefecture

#### ● Osato Regional Konan Clean Center



Project name Konan Clean Center Core Equipment Improvement Project  
 Capacity Incineration facility: 100 tons per day (50 tons per day × 2 units)  
 Location Saitama Prefecture

#### ● Sakado West Disposal Center



Project name Sakado West Disposal Center Incineration Facility Primary Equipment Improvement Project  
 Capacity Incineration facility: 80 tons per day (40 tons per day × 2 units)  
 Power output: 160 kW  
 Location Saitama Prefecture

## Main Recent Projects

### Energy plants

#### ● Ichinohe Forest Power Co., Ltd.



Project name Biomass Power Plant Construction Project  
Capacity Fuel: Wood fuel  
Steam conditions (normal operation):  
28 tons per hour × 5.98 MPaG × 425°C  
Power output: 6,250 kW  
Location Iwate Prefecture

#### ● Ariake Green Energy Co., Ltd.



Project name Arao Biomass Power Plant New Construction Project  
Capacity Fuel: Wood fuel  
Steam conditions (normal operation):  
29.2 tons per hour × 6.0 MPaG × 425°C  
Power output: 6,250 kW  
Location Kumamoto Prefecture

#### ● Sanyo Paper MFG. Co., Ltd.



Project name Biomass Boiler Generation Equipment Installation Project  
Capacity Fuel: Biomass fuel  
Steam conditions (normal operation):  
70 tons per hour × 6.0 MPaG × 460°C  
Power output: 16,700 kW  
Location Tottori Prefecture

#### ● Hanamaki Biomass Energy Co., Ltd.



Project name Biomass Power Plant Construction Project  
Capacity Fuel: Wood fuel  
Steam conditions (normal operation):  
28 tons per hour × 5.98 MPaG × 425°C  
Power output: 6,250 kW  
Location Iwate Prefecture

#### ● Shin Tokai Paper Co., Ltd., Shimada Mill



Project name Boiler and Turbine Equipment Installation Project  
Capacity Fuel: Wood fuel, RPF  
Steam conditions (normal operation):  
100 tons per hour × 6.0 MPaG × 460°C  
Power output: 23,040 kW  
Location Shizuoka Prefecture

#### ● Osaka Soda Co., Ltd. (via Daiso Engineering Co., Ltd.)



Project name RPF Boiler Plant Installation Project  
Capacity Fuel: RPF  
Location Okayama Prefecture

### Water treatment plants

#### ● Nishinomiya City Edagawa Sewage Treatment Plant



Project name Edagawa Sewage Treatment Plant Rapid Filtration Facility Machinery and Equipment New Construction Project  
Capacity Treatment volume: 29,500 m<sup>3</sup> per day  
Type: Moving-bed upflow continuous sand filter  
Specifications: M60 × 10 units × 2 basins (high-speed type)  
Location Hyogo Prefecture

#### ● Uji City Higashiujii Sewage Treatment Plant



Project name Uji City Higashiujii Sewage Treatment Plant Water Treatment Equipment Project No. 16  
Capacity Treatment volume: 3,650 m<sup>3</sup> per day  
Treatment method: Biological nitrogen removal with agglomerating agent  
Specifications: Low-power vertical agitator, aeration system  
Location Kyoto Prefecture

#### ● Tatsuno City Matsubara Preprocessing Plant



Project name Matsubara Preprocessing Plant No. 1 Thickener Tank Scraper Update Project  
Capacity Type: Center-drive suspended type  
Specifications: 17,900 mm diameter × 1 unit  
Location Hyogo Prefecture

#### ● Nagoya City Tsuyuhashi Sewage Treatment Plant



Project name Tsuyuhashi Sewage Treatment Plant Water Treatment Equipment Project (No. 3)  
Capacity Treatment volume: 80,000 m<sup>3</sup> per day  
Type: Moving-bed upflow continuous sand filter  
Specifications: M60 × 6 units × 8 basins (requiring addition of agglomeration agent)  
Location Aichi Prefecture

### Overseas energy plants

#### ● Rajburi Sugar Co., Ltd.



Project name N-5000H Bagasse-Fired Boiler  
Capacity Fuel: Bagasse  
Number of boilers: 1  
Steam conditions (normal operation):  
150 tons per hour × 4.2 MPaG × 450°C  
Location Ratchaburi, Thailand